

# The Genesis of Chua's Circuit

Leon O. Chua

## The Genesis of Chua's Circuit

Following a *non-technical* personal reminiscence of the author's conception of Chua's circuit, this paper presents the systematic sequence of *technical* steps which the author used to design his chaotic circuit. The design procedure, though straightforward in nature, could not have been concocted without a working knowledge of several crucial properties of nonlinear circuits and their physical realizations.

## Die Entstehung der Chua-Schaltung

Anhand eines persönlichen, *nichttechnischen* Rückblicks auf die Grundgedanken des Autors zur Chua-Schaltung stellt die Arbeit die systematische Folge der *technischen* Schritte dar, die ihn zum Entwurf dieser chaotischen Schaltung führten. Der Entwurfsvorgang ist an sich recht einfach, erforderte aber dennoch die Erfahrung und Kenntnis verschiedener Kerneigenschaften nichtlinearer Schaltungen und ihrer physikalischen Realisierungen.

## 1. Reminiscence: A Historical Anecdote

The event which led to the discovery of Chua's circuit took place in the laboratory of Professor T. Matsumoto of Waseda University on a late October afternoon in 1983, the day after my arrival in Tokyo to begin serving my JSPS (Japan Society for Promotion of Science) fellowship. There, in a well-orchestrated and instrument laden corner of Matsumoto's laboratory I was to have witnessed a live demonstration of presumably the world's first successful electronic circuit realization of the Lorenz Equations, on which Professor Matsumoto's research group had toiled for over a year. It was indeed a remarkable piece of electronic circuitry. It was painstakingly breadboarded to near perfection, exposing neatly more than a dozen IC components, and embellished by almost as many potentiometers and trimmers for fine tuning and tweaking their incredibly sensitive circuit board. There would have been no need for inventing a more robust chaotic circuit had Matsumoto's Lorenz Circuit worked. It did not. The fault lies not on Matsumoto's lack of experimental skill, but rather on the dearth of a critical nonlinear IC component with a near-ideal characteristic and a sufficiently large dynamic range; namely, the analog multiplier. Unfortunately, this component was the key to building an autonomous chaotic circuit in 1983. Only two autonomous systems of ordinary differential equations were generally accepted then as being chaotic, namely.

### The Lorenz Equations

$$\begin{aligned}\dot{x} &= -\alpha(x-y) \\ \dot{y} &= \beta x - y - xz \\ \dot{z} &= xy - \gamma z\end{aligned}$$

### and The Rössler Equations

$$\begin{aligned}\dot{x} &= -y - z \\ \dot{y} &= x + \alpha y \\ \dot{z} &= \beta + z(x - \gamma)\end{aligned}$$

where  $\alpha$ ,  $\beta$  and  $\gamma$  are parameters. Note that the nonlinearity in both systems is a function of two variables; namely, the product function.

Prior to 1983, the conspicuous absence of a reproducible functioning chaotic circuit or system seems to suggest that chaos is a pathological phenomenon that can exist only in mathematical abstractions, and in computer simulations of contrived equations. Consequently, electrical engineers in general, and nonlinear circuit theorists in particular, have heretofore paid little attention to a phenomenon which many had regarded as an esoteric curiosity. Such was the state of mind among the nonlinear circuit theory community, circa 1983. Matsumoto's Lorenz Circuit was to have turned the tide of indifference among nonlinear circuit theorists. Viewed from this historical perspective and motivation, the utter disappointments that descended upon all of us on that uneventful October afternoon was quite understandable. So profound was this failure that the wretched feeling persisted in my subconscious mind till about bedtime that evening. Suddenly it dawned upon me, that since the main mechanism which gives rise to chaos, in both the Lorenz and the Rössler Equations, is the presence of at least two *unstable* equilibrium points – 3 for the Lorenz Equations and 2 for the Rössler Equations – it seems only prudent to design a simpler and more robust circuit having these attributes.

Having identified this alternative approach and strategy, it becomes a simple exercise in elementary nonlinear circuit theory [2] to enumerate systematically *all* such circuit candidates, of which there were only 8 of them, and then to systematically eliminate those that, for one reason or another, can not be chaotic. This simple exercise quickly led to two contenders, which upon an application of some educated intuition, tempered by 2 decades of daily exposure to nonlinear circuit phenomena, finally led me to the circuit in Fig. 1. The entire enumeration and elimination process was carried out in less than an hour, in the form of nearly illegible circuit diagrams that I had scribbled on napkins and blank edges of used envelopes. I had to resort to these makeshifts because no paper could be found at that late hour in the dormitory that I had moved into only the night before.

Received December 10, 1991.

Prof. Dr. L. O. Chua, Department of Electrical Engineering, University of California, Berkeley, California 94720, USA.

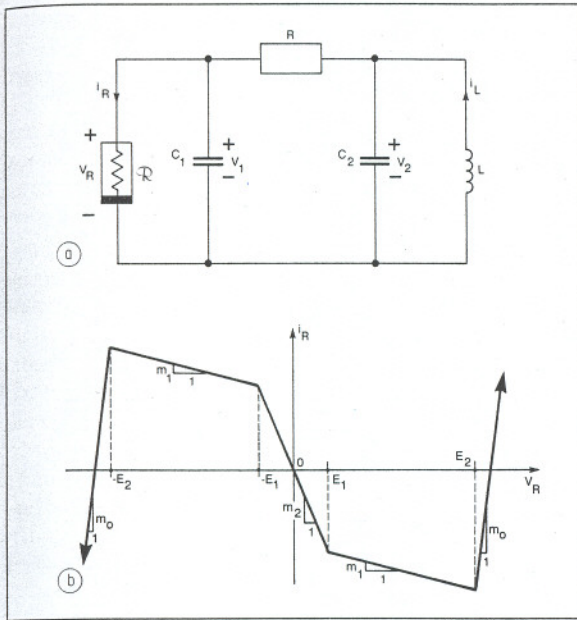

Fig. 1. Chua's circuit (a) and the 5-segment  $v_R - i_R$  characteristic (b) for the nonlinear resistor  $\mathcal{R}$ . For computer simulations, chaos can be observed with only the 3 inner negative-slope segments. The small-signal equivalent circuit corresponding to an equilibrium point lying on any one of these 3 segments is a negative resistance.

The next morning I presented my proposed circuit to Matsumoto and instructed him to choose the value of  $R$  so that its load line [2] would intersect the 3 inner segments having a *negative* slope in Fig. 1(b).

Matsumoto immediately programmed the circuit equations into his computer. Shortly after that, greatly excited, he came running to my office and jubilantly announced that he had found a strange attractor! Matsumoto's extreme excitement at that instant was not unlike that of a little boy's first jump into a swimming pool, for he has had no prior experience with either piecewise-linear dynamic circuits, or nonlinear oscillations, let alone strange attractors.

For several months after this episode, Matsumoto continued to simulate my circuit over a wider range of circuit parameters, and to double check his computer data to ensure that the strange attractor he had observed was not in fact an artifact of his rather unsophisticated computer program, which was written in BASIC. In spite of my numerous proddings, he had refrained from actually breadboarding my circuit since his research group has never synthesized a prescribed non-monotonic  $v-i$  characteristic before. Subsequently, I wrote to Zhong Guo Qin and Farhad Ayrom, who were members of my Nonlinear Electronics Laboratory in Berkeley, and suggested that they apply the synthesis procedure we had developed earlier to build this circuit. Their breadboard worked with virtually no fine tuning. Consequently, Zhong & Ayrom became the first researchers to have documented experimentally-observed chaos from Chua's circuit [17].

(The following section presents a technical version of the design episode alluded to in the preceding narrative.)

## 2. The Nonlinear Circuit Theory behind Chua's Circuit

### 2.1 Circuit Specifications

Since our goal is to build an autonomous electronic circuit which exhibits a chaotic electronic natural behavior, we can formulate our circuit specifications as follows:

Design a *physically realizable* autonomous circuit having exactly two or three *unstable* equilibrium points. The circuit should contain the least possible number of 2-terminal linear passive resistors, inductors, and capacitors, and exactly one 2-terminal nonlinear resistor characterized by an *eventually-passive, piecewise-linear, voltage-controlled  $v-i$  characteristic*.

Clearly, the nonlinear resistor must be *active* in order for the circuit to become chaotic. In other words, the  $v-i$  characteristic must have a non-empty intersection with the open 2nd quadrant, and/or with the open 4th quadrant. However, in order for such a nonlinear resistor to be physically realizable, it must be *eventually passive* in the sense that its  $v-i$  characteristic must lie exclusively in the 1st and the 3rd quadrants outside of some circle of arbitrarily large but finite radius.

Note that we have stipulated that the  $v-i$  characteristic be *piecewise-linear* for two strategic reasons. First, we have had extensive experience on synthesizing piecewise-linear characteristics, having published several papers on this subject, e.g. [3] and [4]. Secondly, we have had extensive experience in decomposing the dynamics of piecewise-linear dynamic circuits into the analysis of several linear (or strictly speaking, affine) systems [2], [8] and [9].

We have also stipulated that the nonlinear resistor be *voltage-controlled* because it is easier to synthesize such elements using op-amps and pn-junction diodes as building blocks [5], [10].

### 2.2 Systematic Design Procedure

Just like designing any circuit to satisfy a prescribed set of specifications, Chua's circuit was designed using a step-by-step systematic synthesis procedure.

#### 1) Determining the Minimum Number of Circuit Elements

An autonomous system of ordinary differential equations having less than 3 state variables can *not* be chaotic [13]. Let us therefore choose 3 linear passive energy storage elements for our circuit. Since the specifications allow only one nonlinear 2-terminal resistor, the remaining elements for our circuit are linear passive resistors. We do not need any independent

sources since the nonlinear resistor, being active, will already have an internal power supply. The number of linear resistors can be minimized by applying standard equivalent circuit techniques to the resulting circuit topology, which we determine next.

2) Determining the Circuit Topology

Let us extract the 3 linear energy storage elements and the 2-terminal nonlinear resistor  $\mathcal{R}$  and connect them across the ports of a 4-port  $N_R$ , made of 2-terminal linear passive resistors. Depending on our choice of the type of energy storage elements, there are 4 distinct circuit configurations, as shown in Fig. 2. We can immediately eliminate the RC circuit configuration Fig. 2(a), and the RL circuit configuration of Fig. 2(b), because two-element kind reciprocal circuits can not oscillate, let alone become chaotic [6]. The remaining two circuit configurations in Fig. 2 are dual of each other, and hence are equally valid candidates. Let us choose the last circuit in Fig. 2(d) because high quality and tunable precision inductors are much more expensive than capacitors.

Having chosen the circuit configuration of Fig. 2(d), and recalling that the nonlinear resistor  $\mathcal{R}$  is voltage-controlled (from our specifications), it immediately follows from standard circuit modeling techniques [7] that except for the rather inflexible case where the two capacitors formed a loop with  $\mathcal{R}$ , one of the two capacitors must necessarily be connected across  $\mathcal{R}$ , so that the circuit configuration in Fig. 2(d) can be further simplified to that shown in Fig. 3(a), where  $N_R$  is now a 3-port made exclusively of 2-terminal linear passive resistors.

At DC equilibriums, the capacitors can be replaced by open circuits and the inductor by a short circuit, as shown in Fig. 3(b). Since the resulting one-port  $N_0$  contains only 2-terminal linear passive resistors, it can be replaced by a Thevenin equivalent resistance  $R_0 > 0$  as shown in Fig. 3(c). Each intersection between the load line  $v_R = -R_0 i_R$  with the  $v_R - i_R$  characteristic of  $\mathcal{R}$  (yet to be determined) identifies the location of an equilibrium point of the circuit. Since the Specifica-

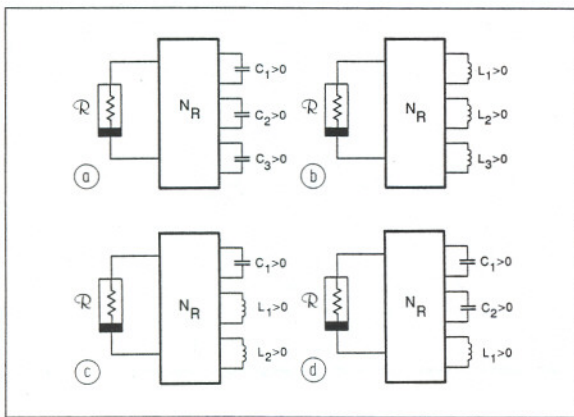

Fig. 2. Four distinct configurations involving 3 energy storage elements. The 4-port  $N_R$  is made of 2-terminal linear passive resistors.

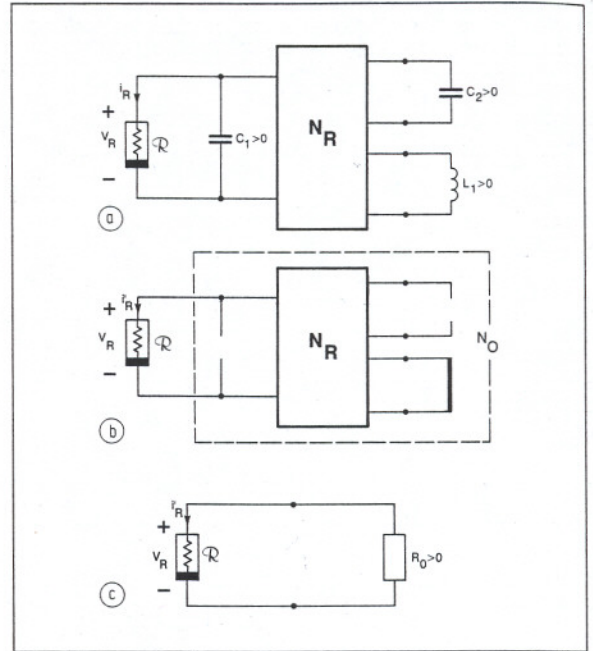

Fig. 3. (a) Circuit configuration which defines a well-posed circuit having 2 linear capacitors, 1 linear inductor, a 2-terminal non-monotonic voltage-controlled resistor, and linear passive resistors. (b) the DC equivalent circuit associated with the circuit in (a). (c) The 1-port  $N_0$  in (b) is equivalent to a single linear passive resistance  $R_0 > 0$ . Since  $R_0 > 0$ , the load line has a negative slope in the  $v_R - i_R$  plane.

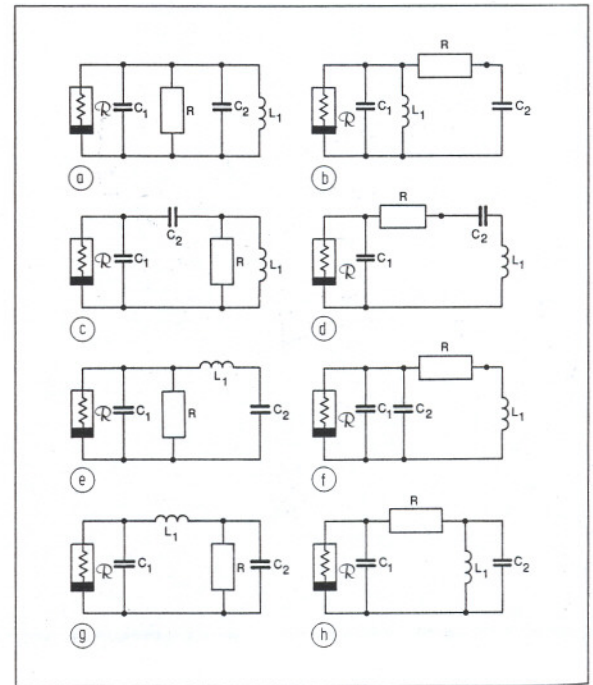

Fig. 4. Assuming the linear 3-port  $N_R$  in Fig. 3(a) contains a single linear positive resistance  $R > 0$ , there are only 8 distinct circuit topologies.

tions called for the use of a minimum number of linear resistors, let us assume that  $N_R$  contains only one linear resistor  $R > 0$ . Having made this simplifying assumption, the circuit configuration of Fig. 3(a) can assume only 8 distinct topologies, as shown in Fig. 4. Our next task is to choose the most promising candidate.

The DC equilibrium circuit corresponding to the 8 circuit topologies in Fig. 4 are shown in Fig. 5. An examination of these topologies shows that the circuits in Figs. 5(a) and (b) can be eliminated from further consideration because the equivalent linear resistor  $R_0$  in each case is a short circuit. The circuit in Fig. 5(c) and (d) can also be eliminated because  $R_0$  in this case is an open circuit. For the remaining 4 circuits, the one shown in Fig. 4(e) can also be eliminated because the linear resistor  $R$  is in parallel with the nonlinear resistor  $\mathcal{R}$ , and can therefore be "absorbed" within  $\mathcal{R}$ , thereby resulting in an open circuit for  $R_0$ . We can likewise eliminate the circuit shown in Fig. 4(f) because the two parallel capacitors  $C_1$  and  $C_2$  can be replaced by an equivalent capacitor, thereby resulting in a second-order circuit, which can not be chaotic. We are finally left with only two candidates, Figs. 4(g) and 4(h), both of which have  $R_0 = R > 0$ .

There is no sound technical reason to favor one candidate over the other at this point. However, the presence of the  $L_1 C_2$  resonant sub circuit on the right hand side of Fig. 4(h) does provide an advantage, since its oscillatory mechanism is often a precursor to chaos. Consequently, let us choose the circuit in Fig. 4(h) as our most likely circuit candidate for chaos.

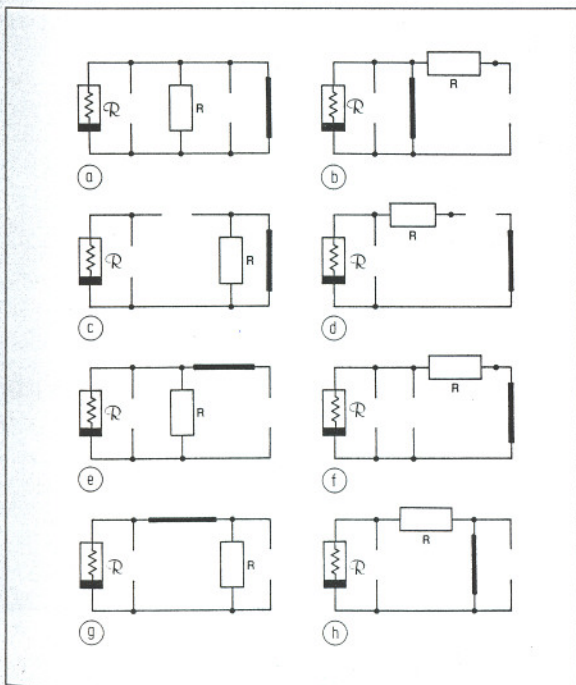

Fig. 5. The DC equilibrium circuits associated with the 8 chaotic circuit candidates from Fig. 4.

### 3) Determining the $v_R - i_R$ Characteristic

Our final task is to determine the appropriate nonlinearity for  $\mathcal{R}$  in order to satisfy the specifications that the circuit must have exactly two, or three, *unstable* equilibrium points. Since, except for the nonlinear resistor  $\mathcal{R}$ , all circuit elements are *passive*, and hence the instability condition implies that each equilibrium point must lie on a segment of the piecewise-linear  $v_R - i_R$  characteristic that has a *negative* slope. This negative-slope condition is equivalent to the small-signal equivalent circuit about each equilibrium point being a negative resistance, which is essential for instability [11].

Since  $R_0 > 0$ , the load line is a straight line (through the origin) with a negative slope equal to  $G = -1/R_0 < 0$ . In order to have 2 unstable equilibrium points, there are only 4 distinct types of continuous 2-segment piecewise-linear characteristics that have a negative slope for both segments, and which could intersect the load line at 2 points, including the origin, as depicted in Figs. 6 and 7. The characteristics in Figs. 6(a) and 7(a) can be eliminated because they are not voltage-controlled functions. The two remaining characteristics in Figs. 6(b) and 7(b), which are dual of each other, are however viable candidates. Unfortunately, they are not eventually passive. The simplest eventually-passive  $v_R - i_R$  characteristic which contains Figs. 6(b) and 7(b) as a subset are shown in Figs. 8(a) and (b), respectively. Since they are dual of each other, either one can be chosen. Since this circuit has only 2 unstable equilibrium points, we could expect that any strange attractor from this circuit would have a structure that resembles the Rössler attractor [1].

To obtain 3 unstable equilibrium points, as in the Lorenz Equations, only two distinct types of continuous 3-segment piecewise-linear characteristic, with a negative slope for each segment, could satisfy the instability condition, as depicted in Figs. 9(a) and (b), respectively. The characteristic in Fig. 9(a) can be eliminated because it is not a voltage-controlled function. The remaining characteristic in Fig. 9(b) is, however, perfectly valid in so far as satisfying the instability condition is concerned. However, it is not eventually passive. The simplest eventually-passive piecewise-linear characteristic which contains Fig. 9(b) as a subset is the 5-segment characteristic shown in Fig. 10.

Although the  $v_R - i_R$  characteristics given in Figs. 8(a), 8(b), and 10(a) do satisfy both the instability condition and the eventual passivity condition stipulated in the specifications, let us choose the latter for three reasons.

- 1) The characteristics of Fig. 10(a) contains both characteristics of Figs. 8(a) and 8(b) as subsets, and hence if the circuit associated with either Fig. 8(a) or 8(b) has a strange attractor, so will Fig. 10(a). Moreover, the presence of a third unstable equilibrium point in Fig. 10(a) provides the strong possibility for the existence of other strange attractors, thereby making this circuit richer in chaotic dynamics.

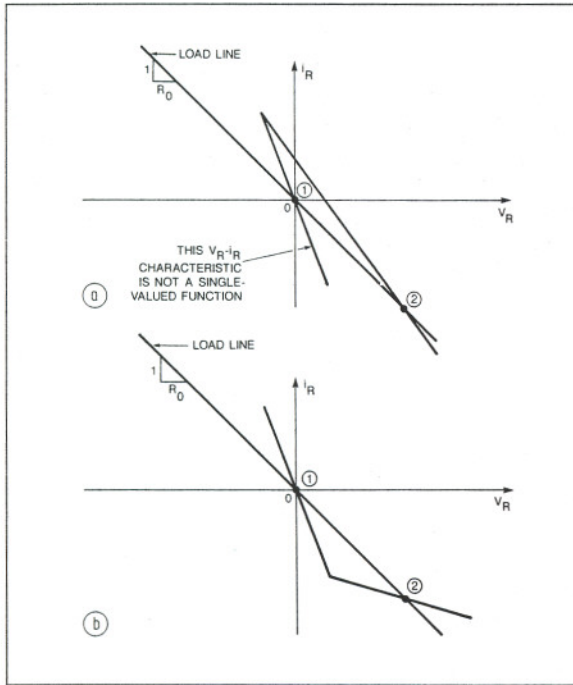

Fig. 6. Only 4 distinct piecewise-linear curves having 2 connected negative-slope segments can exist which intersect the negative-slope load line at exactly two points. The characteristic in (a) is a double-valued function of both  $v_R$  and  $i_R$ . The characteristic in (b) is a single-valued function, whose lower segment, if extended indefinitely, will remain within the 4th quadrant, and is hence not physically realizable.

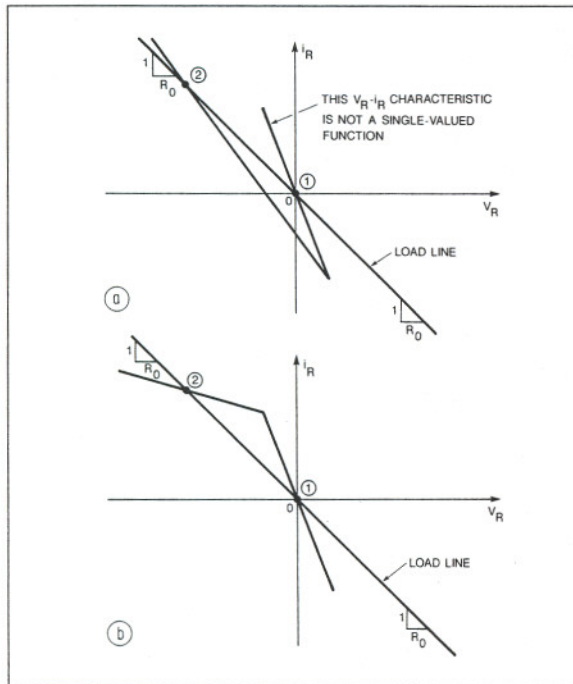

Fig. 7. The remaining piecewise-linear characteristics alluded to in the preceding figure caption are the dual of those in Fig. 6. Consequently, the characteristic in (a) is also a double-valued function of both  $v_R$  and  $i_R$ , while the characteristic in (b) is a single-valued function, whose upper segment, if extended indefinitely, will remain within the 2nd quadrant, and is hence not physically realizable.

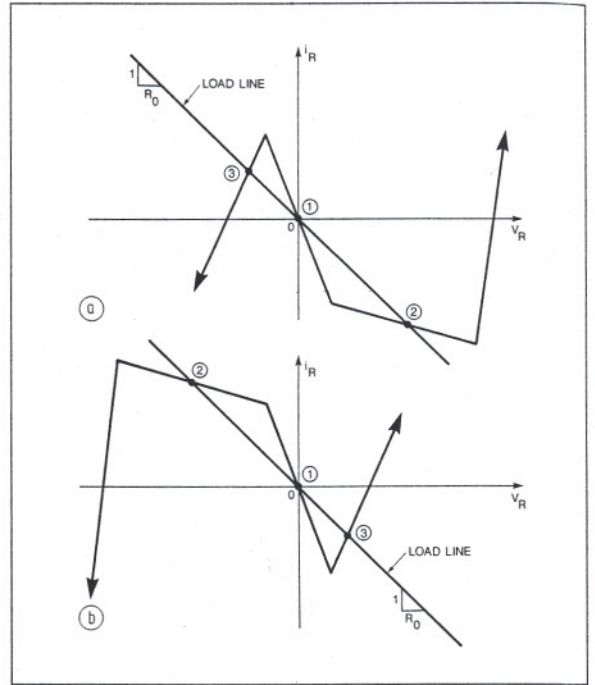

Fig. 8. The 2 dual 4-segment characteristic in (a) and (b) are the simplest eventually passive, hence physically realizable  $v_R - i_R$  characteristic which include that of Figs. 6(b) and 7(b) respectively, as a subset.

- 2) It is actually easier to realize the  $v_R - i_R$  characteristic of Fig. 10(a) because it exhibits *odd* symmetry: there exist simple techniques to synthesize odd-symmetrical  $v - i$  characteristics [2]. Moreover, since the associated state equation will also be odd symmetric, the analytical study of this circuit will be no more complicated than that of the circuit associated with Fig. 8.
- 3) Although the piecewise-linear characteristic of Fig. 8, has two unstable equilibrium points, an extraneous third but *stable* equilibrium point ③ had been inadvertently introduced because this point falls on the positive-slope segment which we have augmented earlier to ensure eventual passivity. While it is theoretically possible to push the breakpoint of this segment as far to the right as possible to prevent it from interfering with the originally intended dynamics, this approach may not be easy to implement in practice in view of the limited cut-in voltage (less than 1 volt) in pn-junction diodes, and the limited saturation voltage (less than 20 volts) in op-amps.

The above considerations therefore suggest that we choose the odd-symmetric 5-segment piecewise-linear function of Fig. 10(a) as the  $v_R - i_R$  characteristic for the nonlinear resistor  $\mathcal{R}$ . Note that the two positive-slope segments we augmented earlier to ensure eventual passivity did not introduce any new equilibrium points, provided the resistance  $R$  is not too large to cause its load line to swing beyond the outermost breakpoints, as depicted in Fig. 10(b). Having made this choice, we obtain the Chua's circuit of Fig. 1.

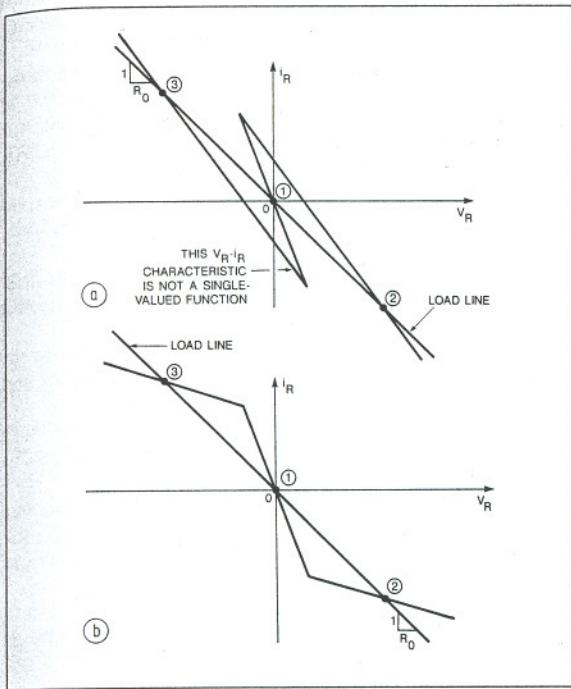

Fig. 9. Only 2 distinct piecewise-linear curves having 3 negative-slope segments can exist which intersect the negative-slope load line at exactly 3 points. The characteristic in (a) is a triple-valued function of both  $v_R$  and  $i_R$ . The characteristic in (b) is a single-valued function of  $v_R$ . However, if the end segments are extended indefinitely, the curve will remain in the 2nd and the 4th quadrants, respectively, and hence is not physically realizable.

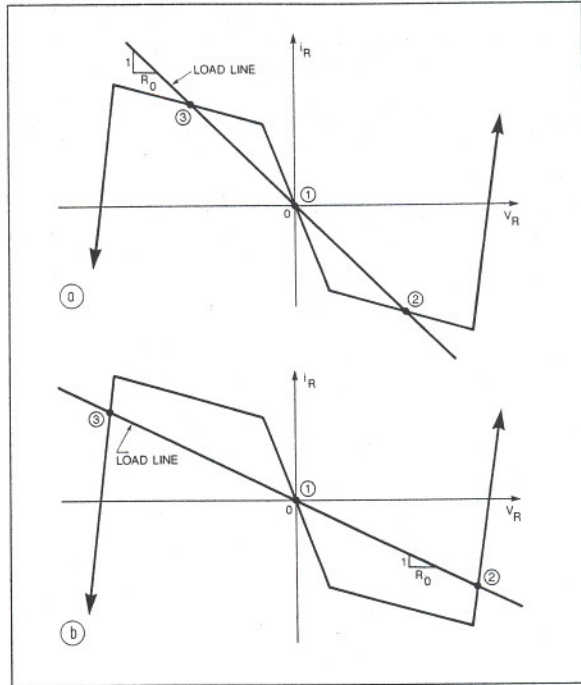

Fig. 10. The simplest 5-segment piecewise-linear characteristic which is eventually passive, and hence physically realizable, and which contains the 3-segment characteristic of Fig. 9(b) as a subset. The load line in (a) intersects this characteristic at 3 points in the negative-slope segments, as called for in the specifications. If the value of  $R_0$  is chosen too large, however, the two outer equilibrium points will fall on the positive-slope outer segments, and become stable equilibrium points, thereby violating the specifications.

### 3. Concluding Remarks

The chaotic circuit of Fig. 1 was first announced in [15] where Matsumoto had named it Chua's Circuit. However, since this seminal article on Chua's Circuit involves only computer simulations where the two end segments needed for physical realization are irrelevant, Matsumoto uses only the 3 negative-slope segments of Fig. 9(b) and refers to this characteristic in his article as a "simplified version" of my original circuit. This sentence by Matsumoto was misleading because the circuit remains unchanged: only the  $v_R - i_R$  characteristic had been truncated to consist of only the negative-slope segments, an obvious observation when viewed from the preceding synthesis procedure. For the more hardware-oriented readers, however, it is important to stress that any electronic circuit realization of this 3-segment characteristic – and there exist many such realizations – will necessarily result in the eventual characteristic *rolling off*, either gently, or abruptly, so that the outermost portion of the characteristic will eventually lie in the 1st and the 3rd quadrants. In the simplest cases, each outermost portion of the  $v_R - i_R$  characteristics will approach a *positive-slope* straight line. Indeed, the measured characteristics of all known electronic circuit realizations [14],

[15], [17] of the 3-segment  $v_R - i_R$  characteristic of Fig. 9(b) are virtually identical to the 5-segment characteristic shown in Fig. 1(b).

As a final remark, we wish to point out that the contending circuit candidate in Fig. 4(g) which we had abandoned earlier in favor of Chua's Circuit is interesting in its own right. In particular, if we add a linear passive resistor in series with the inductor  $L$ , in Fig. 4(g), we would obtain the canonical realization [12] of Chua's Circuit family [16]. More than 30 distinct strange attractors have so far been discovered from this canonical circuit!

### Appendix: A Chronological Bibliography on Chua's Circuit

Matsumoto, T.: A chaotic attractor from Chua's circuit. IEEE Trans. CAS-31, no. 12 (1984), 1055–1058.  
 Zhong, G. Q.; Ayrom, F.: Experimental confirmation of chaos from Chua's circuit. Int. J. Circuit Theory Appl. 13, no. 11 (1985), 93–98.  
 Zhong, G. Q.; Ayrom, F.: Periodicity and chaos in Chua's circuit. IEEE Trans. CAS-32, no. 5 (1985), 501–503.  
 Matsumoto, T.; Chua, L. O.; Komuro, M.: The Double Scroll. IEEE Trans. CAS-32, no. 8 (1985), 797–818.

- Matsumoto, T.; Chua, L. O.; Komuro, M.: The Double Scroll bifurcations. *Int. J. Circuit Theory Appl.* **14**, no. 1 (1986), 117–146.
- Matsumoto, T.; Chua, L. O.; Tokumasu, K.: Double Scroll via a two-transistor circuit. *IEEE Trans. CAS-33*, no. 8 (1986), 828–835.
- Ayrom, F.; Zhong, G. Q.: Chaos in Chua's circuit. *IEE Proceedings* **133**, no. 6 (1986), 307–312.
- Chua, L. O.; Komuro, M.; Matsumoto, T.: The Double Scroll family, parts I and II. *IEEE Trans. CAS-33*, no. 11 (1986), 1073–1118.
- Kahlert, C.; Chua, L. O.: Transfer maps and return maps for piecewise-linear and three-region dynamical systems. *Int. J. Circuit Theory Appl.* **15**, no. 1 (1987), 23–49.
- Matsumoto, T.; Chua, L. O.; Komuro, M.: Birth and death of the Double Scroll. *Physica* **24D** (1987), 97–124.
- Ogorzałek, M. J.: Chaotic regions from Double Scroll. *IEEE Trans. CAS-34*, no. 2 (1987), 201–203.
- Broucke, M. E.: One-parameter bifurcation diagram for Chua's circuit. *IEEE Trans. CAS-34*, no. 3 (1987), 208–209.
- Matsumoto, T.; Chua, L. O.; Tokunaga, R.: Chaos via torus breakdown. *IEEE Trans. CAS-34*, no. 3 (1987), 240–253.
- Wu, S.: Chua's circuit family. *Proceedings IEEE* **75**, no. 8 (1987), 1022–1032.
- Parker, T. S.; Chua, L. O.: The dual Double Scroll equation. *IEEE Trans. CAS-34*, no. 9 (1987), 1059–1073.
- Mees, A. I.; Chapman, P. B.: Homoclinic and heteroclinic orbits in the Double Scroll attractor. *IEEE Trans. CAS-34*, no. 9 (1987), 1115–1120.
- Kahlert, C.: The range of transfer and return maps in three-region piecewise-linear dynamical systems. *Int. J. Circuit Theory Appl.* **16**, no. 1 (1988), 11–23.
- Kahlert, C.: Dynamics of the inclusions appearing in the return maps of Chua's circuit – 1. the creation mechanism. *Int. J. Circuit Theory Appl.* **16**, no. 1 (1988), 29–46.
- Komuro, M.: Normal forms of continuous piecewise-linear vector field and chaotic attractors: Part I. *Japan. J. Appl. Math.* **5**, no. 2 (1988), 257–304.
- Komuro, M.: Normal forms of continuous piecewise-linear vector field and chaotic attractors: Part II. *Japan. J. Appl. Math.* **5**, no. 3 (1988), 503–549.
- Kahlert, C.: The chaos producing mechanism in Chua's circuit. *Int. J. Circuit Theory Appl.* **16**, no. 2 (1988), 227–232.
- Matsumoto, T.; Chua, L. O.; Ayaki, K.: Reality of chaos in the Double Scroll circuit: A computer-assisted proof. *IEEE Trans. CAS-35*, no. 7 (1988), 909–925.
- Silva, C. P.; Chua, L. O.: The overdamped Double Scroll family. *Int. J. Circuit Theory Appl.* **16**, no. 3 (1988), 233–302.
- Bartissol, P.; Chua, L. O.: The Double Hook. *IEEE Trans. CAS-35*, no. 12 (1988), 1512–1522.
- Huang, A.: A study of the chaotic phenomena in Chua's circuit. In: *Proceedings of the ISCAS, Helsinki, 1988*, 273–276.
- Tokunaga, R.; Matsumoto, T.; Komuro, M.; Chua, L. O.; Miya, K.: Homoclinic linkage: A new bifurcation mechanism. *Proceedings ISCAS, Seattle, 1989*, 826–829.
- Tokunaga, R.; Matsumoto, T.; Ida, T.; Miya, K.: Homoclinic linkage in the Double Scroll circuit and the cusp-constrained circuit. In: *The Study of Dynamical Systems* (N. Aoki, ed.), Singapore: World Scientific (1989), 192–209.
- Chua, L. O.; Lin, G. N.: Intermittency in a piecewise-linear circuit. *IEEE Trans. CAS-38*, no. 5 (1990), 510–520.
- Blazquez, C. M.; Tuma, E.: Dynamics of the Double Scroll circuit. *IEEE Trans. CAS-37*, no. 5 (1990), 589–593.
- Chua, L. O.; Lin, G. N.: Canonical realization of Chua's circuit family. *IEEE Trans. CAS-37*, no. 7 (1990), 885–902.
- Spany, V.; Pivka, L.: Boundary surfaces in sequential circuits. *Int. J. Circuit Theory Appl.* **18**, no. 4 (1990), 349–360.
- Komuro, M.: Bifurcation equations of 3-dimensional piecewise-linear vector fields. In: *Bifurcation Phenomena in Nonlinear Systems and Theory of Dynamical Systems* (H. Kawakami, ed.), Singapore: World Scientific (1990), 113–123.
- Lozi, R.; Ushiki, S.: Confinors and bounded-time patterns in Chua's circuit and the Double Scroll family. *Int. J. Bifurcation and Chaos* **1**, no. 1 (1991), 119–138.
- Komuro, M.; Tokunaga, R.; Matsumoto, T.; Hotta, A.: Global bifurcation analysis of the Double Scroll circuit. *Int. J. Bifurcation and Chaos* **1**, no. 1 (1991), 139–182.
- Murali, K.; Lakshmanan, M.: Bifurcation and chaos of the sinusoidally-driven Chua's circuit. *Int. J. Bifurcation and Chaos* **1**, no. 2 (1991), 369–384.
- Lozi, R.; Ushiki, S.: Co-existing chaotic attractors in Chua's circuit. *Int. J. Bifurcation and Chaos* **1**, no. 4 (1991), 923–926.
- Kahlert, C.: Heteroclinic orbits and scaled similar structures in the parameter space of the Chua oscillator. In: *Chaotic Hierarchy* (G. Baier and M. Klein, eds.), Singapore: World Scientific (1991), 209–234.
- Dabby, D. S.: The buffalo horn and strange behavior in third order autonomous circuits. Master's thesis, Massachusetts Institute of Technology, Electrical Engineering and Computer Science. 142 pages.
- Cruz, J.; Chua, L. O.: A CMOS IC nonlinear resistor for Chua's circuit. Memorandum, Electronics Research Laboratory, University of California, Berkeley, Memo no. M92/16, February 1992.
- Genesisio, R.; Tesi, A.: Harmonic balance approach for chaos prediction: the Chua's circuit. *Int. J. Bifurcation and Chaos* **2**, no. 1 (1992), in press.
- Kennedy, M. P.: Robust OP Amp realization of Chua's Circuit. *Frequenz* **46**, no. 3–4 (1992), 66–80.
- Madan, R. (Guest Editor): Special issue on Chua's circuit: A paradigm for chaos, Part I. *J. Circuit, Systems, and Computers* **2**, no. 1 (1993) (to appear in march 1993).
- Madan, R. (Guest Editor): Special issue on Chua's circuit: A paradigm for chaos, Part II. *J. Circuit, Systems, and Computers* **2**, no. 2 (1993) (to appear in june 1993).

## References

- [1] Abraham, R. H.; Shaw, C. D.: *Dynamics – The geometry of behavior*. Santa Cruz: Aerial Press, 1981.
- [2] Chua, L. O.: *Introduction to nonlinear circuit theory*. New York: McGraw-Hill, 1969.
- [3] Chua, L. O.: Analysis and synthesis of multivalued memoryless nonlinear networks. *IEEE Trans. CT-15* (1967), 192–209.
- [4] Chua, L. O.: Synthesis of new nonlinear network elements. *Proc. IEEE* **56** (1968), 1325–1340.
- [5] Chua, L. O.; Wong, S.: Synthesis of piecewise-linear networks. *Electronic Circuit and Systems* **2** (1978), 102–108.
- [6] Chua, L. O.: Dynamic nonlinear networks: state-of-the-art. *IEEE Trans. CAS-27* (1980), 1059–1087.
- [7] Chua, L. O.: Device modeling via basic nonlinear circuit elements. *IEEE Trans. CAS-27* (1980), 1014–1044.
- [8] Chua, L. O.; Ying, R.: Finding all solutions of piecewise-linear circuits. *Int. J. Circuit Theory and Appl.* **10** (1982), 201–229.
- [9] Chua, L. O.; Hasler, M.; Neiryneck, J.; Verburgh, P.: Dynamics of a piecewise-linear resonant circuit. *IEEE Trans. CAS-29* (1982), 535–547.

- [10] Chua, L. O.; Ayrom, F.: Designing nonlinear single op-amp circuits: a cookbook approach. *Int. J. Circuit Theory and Appl.* 13 (1985), 235-268.
- [11] Chua, L. O.; Desoer, C. A.; Kuh, E. S.: *Linear and nonlinear circuits*. New York: McGraw-Hill, 1985.
- [12] Chua, L. O.; Lin, G. N.: Canonical realization of Chua's circuit family. *IEEE Trans. CAS-37* (1990), 885-902.
- [13] Guckenheimer, J.; Holmes, P.: *Nonlinear oscillations, dynamical systems, and bifurcations of vector fields*. New York: Springer Verlag, 1983.
- [14] Kennedy, P.: Experimental chaos via Chua's circuit. In S. Vohra, M. Spano, M. Shlesinger, L. Pecora, W. Ditto (Editors), *Proc. of the 1st Experimental Chaos Conference*, World Scientific, 1992, 340-351.
- [15] Matsumoto, T.: A chaotic attractor from Chua's circuit. *IEEE Trans. CAS-31* (1984), 1055-1058.
- [16] Wu, S.: Chua's circuit family. *Proc. IEEE* 75 (1987), 1022-1032.
- [17] Zhong, G. Q.; Ayrom, F.: Experimental confirmation of chaos from Chua's circuit. *Int. J. Circuit Theory Appl.* 13 (1985), 93-98.



**Leon O. Chua** received the S. M. degree from the Massachusetts Institute of Technology in 1961 and the Ph. D. degree from the University of Illinois, Urbana, in 1964. He was also awarded a Doctor Honoris Causa from the Ecole Polytechnique Federale de Lausanne, Switzerland, in 1983 and an Honorary Doctorate from the University of Tokushima, Japan, in 1984.

He is presently a professor of Electrical Engineering and Computer Sciences at the University of California, Berkeley.

Professor Chua's research interests are in the areas of general nonlinear network and system theory. He has been a consultant to various electronic industries in the areas of nonlinear network analysis, modeling, and computer-aided design. He is the author of *Introduction to Nonlinear Network Theory* (New York: McGraw Hill, 1969), and a co-author of the books *Computer-Aided Analysis of Electronic Circuits: Algorithms and Computational Techniques* (Englewood Cliffs, NJ: Prentice-Hall, 1975), *Linear and Nonlinear Circuits* (New York: McGraw-Hill, 1987), and *Practical Numerical Algorithms for Chaotic Systems* (New York: Springer-Verlag, 1989). He has published many research papers in the areas of nonlinear networks and systems.

Professor Chua was elected Fellow of the IEEE in 1974. He served as Editor of the *IEEE Transactions on Circuits and Systems* from 1973 to 1975 and as the President of the IEEE Society on Circuits and Systems in 1976. He is presently the editor of the *International Journal of Bifurcation and Chaos* and a deputy editor of the *International Journal of Circuit Theory and Applications*.

Professor Chua is the holder of five U.S. patents. He is also the recipient of several awards and prizes, including the 1967 IEEE Browder J. Thompson Memorial Prize Award, the 1973 IEEE W. R. G. Baker Prize Award, the 1974 Frederick Emmons Terman Award, the 1976 Miller Research Professorship from the Miller Institute, the 1982 Senior Visiting Fellowship at Cambridge University, England, the 1982/83 Alexander von Humboldt Senior U.S. Scientists Award at the Technical University of Munich, W. Germany, the 1983/84 Visiting U.S. Scientists Award at Waseda University, Tokyo, from the Japan Society for Promotion of Science, the IEEE Centennial Medal in 1985, the 1985 Myril B. Reed Best Paper Prize, and both the 1985 and 1989 IEEE Guillemin-Cauer Prize.

In the fall of 1986, Professor Chua was awarded a Professor Invité International Award at the University of Paris-Sud from the French Ministry of Education.

## Book-Review · Buchbesprechung

**P. Bhartia, K. V. S. Rao, R. S. Tomar: Millimeter-Wave Microstrip and Printed Circuit Antennas.** Artech House, Boston/USA, 1991, 322 Seiten, 184 Bilder, 10 Tabellen, 16 cm x 23 cm, geb. £ 55.00. ISBN 0-89006-333-8.

Die drei Autoren dieses Bandes rekrutieren sich aus einem kanadischen Zentrum der Verteidigungsforschung, der Universität von Ottawa und der Industriefirma Bell-Northern in Ottawa/Kanada. Er zielt auf die allgemeine Miniaturisierung von Radargeräten hin, was zu den mm-Wellenlängen führen muß, speziell auf Gruppenantennen in gedruckter (monolithischer) Schaltungstechnik. Arbeiten von zehn Jahren sind zusammengefaßt, um „Ingenieure in der Praxis“ beim Entwurf zu unterstützen.

Begrenzend für die Brauchbarkeit solcher Gruppen wirken Substrate, besonders deren Verluste und das Aufkommen von Oberflächenwellentypen bei hohen Werten der Dielektrizitätskonstante (Kap. 1). Der Vergleich von analytischen und numerischen Berechnungshilfen folgen in Kap. 2, wobei auf Ableitungen auf Kosten von Literaturhinweisen weitgehend verzichtet wird, was dann interessierte Leser wieder auf die Originalarbeiten zurückwirft. Verwirrend wirkt, wenn für die gleiche Leitergeometrie verschiedene Koordinatensysteme verwendet werden (Fig. 3.3, 4.4). Kapitel 3 geht auf die Auswahl des wichtigen Substrat-Materials (Anisotro-

pien!) und weitere Hersteller-Strategien ein. Kapitel 4 ist den speziellen Plättchen-Geometrien (patch) und deren elektrischen Eigenschaften gewidmet, während Kapitel 5 auf die verschiedenen Einkoppelsonden-Arten (Hohlleiter, koaxial, Streifenleitung etc.) eingeht. Weg von den schmalen Bandbreiten, die durch die relativ hohen Güten der Elemente und der zugehörigen Dielektrika problematisch sind, zeigt Kapitel 6 Wege zur Steigerung dieses Parameters und Kapitel 7 beschäftigt sich mit den Gruppen-Topologien bei Steh- und Wanderwellen-Einspeisung. Leider werden dabei so wichtige Grundlagen wie das Einführen von elektrischen und magnetischen „Wänden“ nur flüchtig gestreift.

Mannigfaltige Vergleichstabellen und die vielen Grafiken, in denen die berechneten Kurven mit Messungen sogar verglichen werden, helfen in der Tat beim Entwurf solcher miniaturisierter mm-Wellen-Gruppenantennen unter Berücksichtigung von z. B. des Auftretens blinder Winkel und Flecken (spots) beim (Haupt-)Keulenschwenken mittels elektronisch angesteuerter Phasenschieber.

Der vorliegende Band ist selbst unter der Berücksichtigung der genannten, didaktischen Mängel sicherlich Antenneningenieuren beim Entwurf solcher diffizilen, modernen Gruppenstrahler (phased arrays) eine große Hilfe.

R. Wohlleben